

- > Port size: DN 1,6 and 3
- > Compact design
- > Complete with connector and gasket
- > Solenoid interchangeable without tools (*Click-on®*)
- > Noiseless exhaust
- > Low power consumption
- > International approvals



### Technical features

**Medium:**

Filtered, lubricated resp. non-lubricated air or neutral liquid fluids

**Switching function:**

Normally closed

**Operation:**

Indirectly solenoid actuated

**Mounting:**

Optional, preferably solenoid vertical on top

**Flow direction:**

Determined

**Port size:**

DN 1,6, DN 3

**Operating pressure:**

1 ... 10 bar (14,5 ... 145 psi)

**Fluid temperature:**

-10 ... +60°C (+14 ... +140°F)

**Ambient temperature:**

-10 ... +60°C (+14 ... +140°F)

**Material:**

Body: Aluminium

Seat seal: TPU

Internal parts: Stainless steel, PPS

### Technical datas – standard models

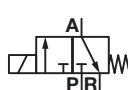
Symbol	Orifice (mm)	Port size			Flow *2) (l/min)	Operating pressure (bar)	Switching time (ms) *3)		Weight (kg)	Model Solenoid in V d.c.	Model Solenoid in V a.c.
		Internal	External R	A			On	Off			
	1,6	G1/4	*1)	G1/4	1,2	1 ... 10	8,5	30,4	0,47	8466000.9101.xxxxx	8466000.9101.xxxxx
	1,6	1/4 NPT	*1)	1/4 NPT	1,2	1 ... 10	8,5	30,4	0,47	8467000.9101.xxxxx	8467000.9101.xxxxx
	3	G1/4	*1)	G1/4	3,3	1 ... 10	15	81,9	0,45	8468000.9151.xxxxx	8468000.9151.xxxxx
	3	1/4 NPT	*1)	1/4 NPT	3,2	1 ... 10	15	81,9	0,45	8469000.9151.xxxxx	8469000.9151.xxxxx

xxxxx Please insert voltage and frequency codes

\*1) Noiseless exhaust

\*2) Cv-value (US) ≈ kv-value x 1,2

\*3) At 6 bar acc. to DIN VDI 3290 with solenoid in d.c.

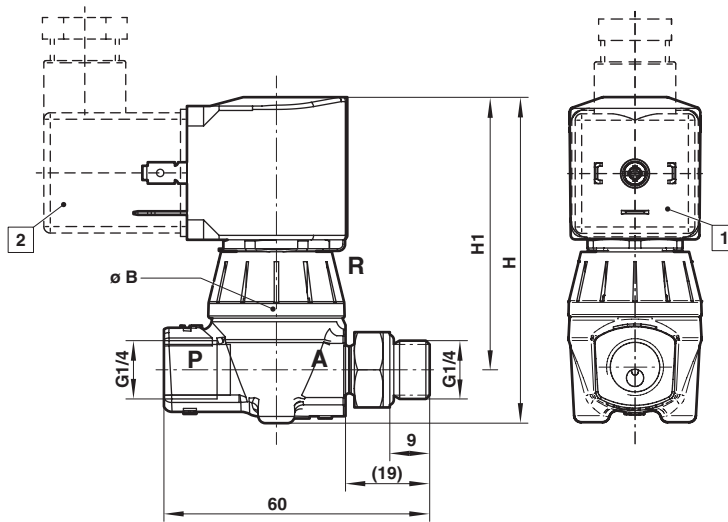

**Dimensions**
**DN 1,6 ... 3**

 Dimensions in mm  
 Projection/First angle

- 1 Solenoid rotatable 360°
- 2 Socket turnable 4 x 90°  
(Socket included)

Orifice (mm)	$\phi B$	H	H1	Model
1,6	31	73,6	61,5	8466000.9101.xxxxx
1,6	31	73,6	61,5	8467000.9101.xxxxx
3	31	91	79	8468000.9151.xxxxx
3	31	91	79	8469000.9151.xxxxx

**Note to Pressure Equipment Directive (PED):**

The valves of this series are according to Art. 4 § 3 of the Pressure Equipment Directive (PED) 2014/68/EU. This means interpretation and production are in accordance to engineers practice wellknown in the member countries. The CE-sign at the valve does not refer to the PED. Thus the declaration of conformity is not longer applicable for this directive.

**Note to Electromagnetic Compatibility Guideline (EEC):**
**Note to EAC marking:**

The EAC-marked products comply with the applicable requirements stated in the technical regulations of the Eurasian Economic Union.